



**MACHINERY**  
ADDING VALUE IN PACKHOUSE SOLUTIONS



# Casepacker

Type: BCP

**VARIOUS  
FILLING  
PATTERNS  
POSSIBLE**

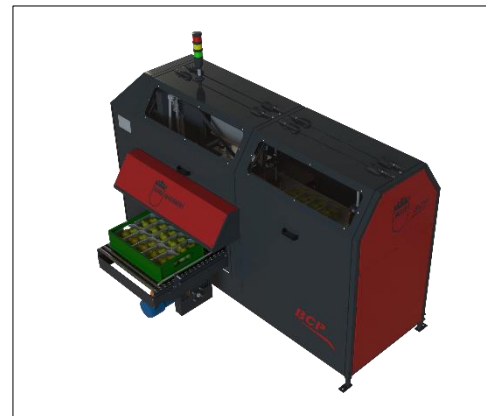

Weihoek 11 • 4416 PX Kruijningen  
T: +31 (0)113 - 50 13 73 • F: +31 (0)113 - 50 21 08  
E: info@burgmachinery.com



[www.burgmachinery.com](http://www.burgmachinery.com)



- Ontworpen voor het automatisch en continue vullen van kratten/ dozen met (verpakt) product.
- Kleine voetafdruk dankzij de compacte bouwwijze.
- Eenvoudige bediening (touchscreen).
- Volledig automatisch aangedreven.
- Diverse vulpatronen mogelijk.



- Designed for automatic and continuous filling of crates/boxes with (packaged) product.
- Small footprint thanks to the compact construction.
- Simple operation (touch screen).
- Fully automatic powered.
- Various filling patterns possible.



- Konzipiert für die automatische und kontinuierliche Befüllung von Kisten/Kartons mit (verpacktem) Produkt.
- Geringer Platzbedarf durch kompakte Bauweise.
- Einfache Bedienung (Touchscreen).
- Vollautomatisch angetrieben.
- Verschiedene Füllmuster möglich.

## Dimension view – Casepacker BCP

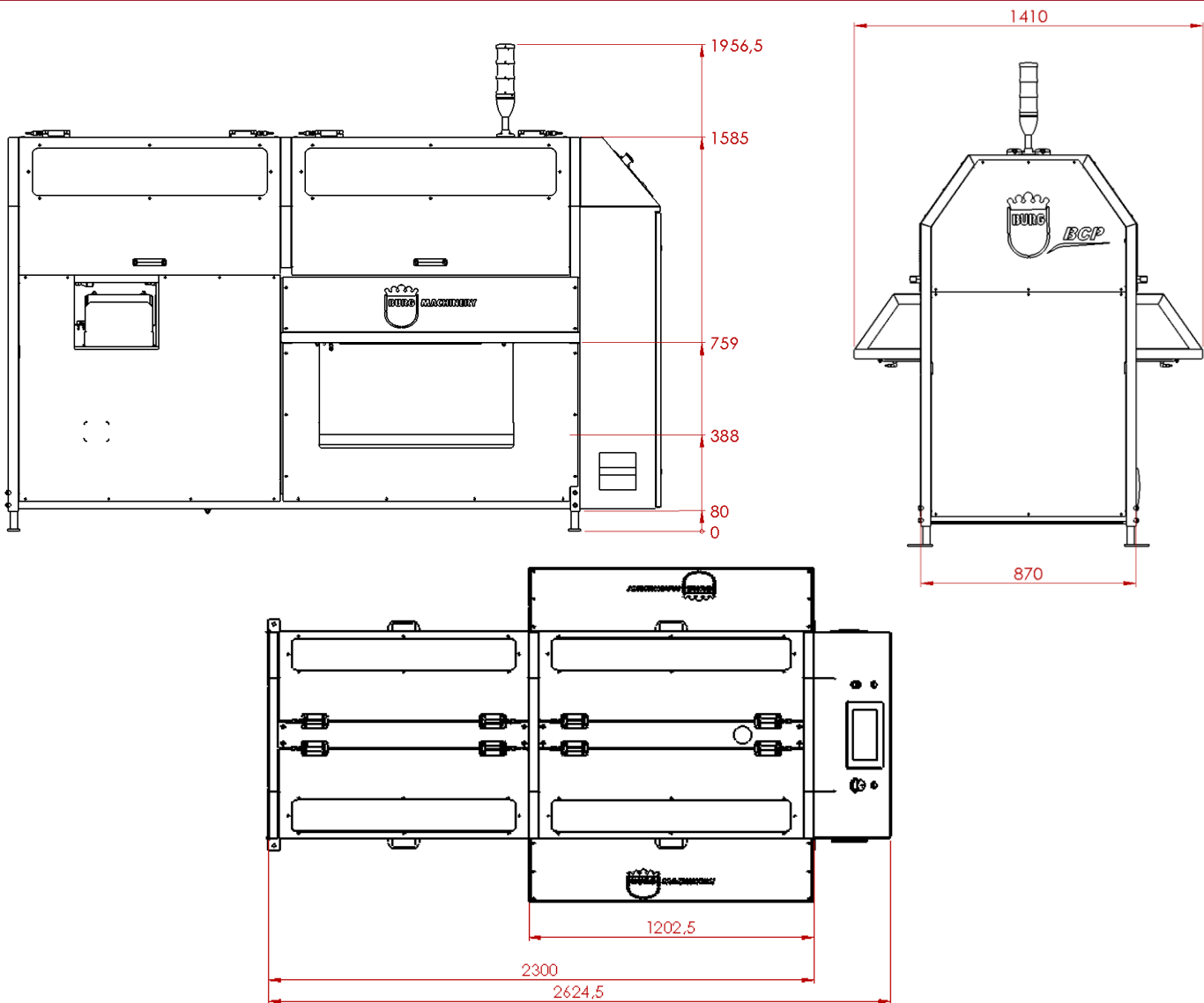

Dealer / vertretung:



Weihoek 11 • 4416 PX Kruijningen  
 T: +31 (0)113 - 50 13 73 • F: +31 (0)113 - 50 21 08  
 E: info@burgmachinery.com



www.burgmachinery.com